

REVISIONS						
REV	ZONE	ECO#	DESCRIPTION	DRAW	APPD	DATE
-			INITIAL RELEASE	KC	PK	11/11/16
A			ADDED RoHS NOTE	KC	PK	2/13/17

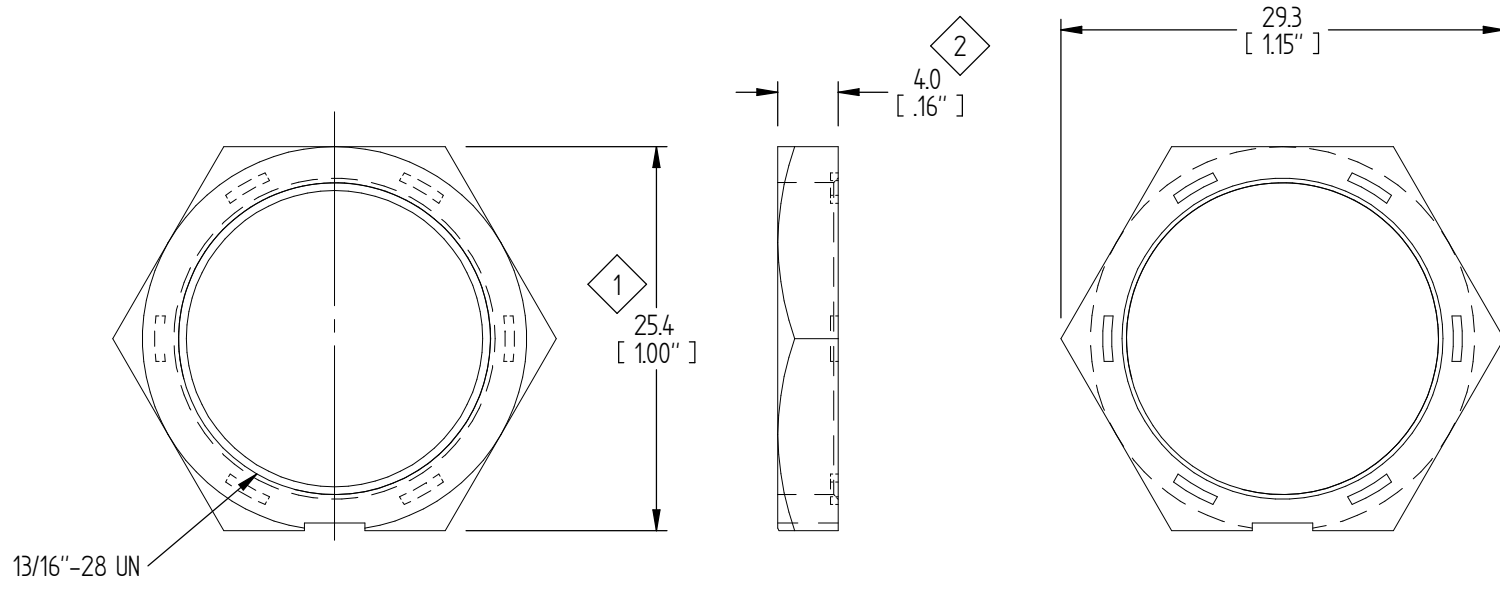

**NOTES:**

1. MATERIAL: NYLON
2. COLOR: BLACK
3. BURR: 0.15mm MAX
4. ITEMS IDENTIFIED WITH DIAMOND (◊...◊) MUST BE INSPECTED.
5. REFERENCE PACKAGING SPECIFICATIONS PER DOC# PKG-001
6. 10 PCS NUT PUT INTO ONE PE BAG
7. RoHS COMPLIANT.



NOTE: CAD GENERATED DRAWING DO NOT UPDATE MANUALLY.

PART NUMBER		IPNT-1316	
TITLE		NUT 13/16 28UN PLASTIC 10PK	
UNLESS OTHERWISE SPECIFIED, DIMENSIONS ARE IN MM		REV A	
TOLERANCE EXCEPT AS NOTED:		DATE 11/11/16	
DECIMAL X #025	XX #01	XXX #005	ANGLES #°
IMPERIAL DIMENSIONS ARE FOR REFERENCE ONLY		ENGINEER	DATE 11/11/16
THIRD ANGLE PROJECTION		APPROVED BY	DATE 11/11/16
DATE CODE 2A589		P.KIM	
SIZE A	SCALE NTS	SHEET 1 OF 1	REV A

2180 Hornig Road, Philadelphia, PA 19116

**NOTICE OF CONFIDENTIALITY**  
THIS DRAWING IS THE PROPERTY OF PEI-Genesis. ALL RIGHTS RESERVED. REPRODUCTION BY ANY MEANS OR DISTRIBUTION TO THIRD PARTIES IS STRICTLY PROHIBITED WITHOUT THE WRITTEN PERMISSION OF AN AUTHORIZED AGENT OF PEI-Genesis.